

DIAGNOSTIC PROCESS

DECEMBER 2020

GUIDE TO DIAGNOSTIC PROCESS AND TOOLS

PLANNING, IMPLEMENTATION,
AND PRODUCTS

Remote Diagnostics

Actionable intelligence
for fleets

Page 8

Scan Tool Tips

Maximize your tool's
features and functionality

Page 15

SUPPLEMENT
BROUGHT TO YOU BY

Professional Distributor

PTEN

Fleet Maintenance

VEHICLE
SERVICE
PROS

SPONSORED BY:

AUTEL®

LAUNCH
TECH USA
CREATE • CHANGE

MATCO
TOOLS

NOREGON.
VEHICLE DATA EXPERTS

pico
Technology

Snap-on®

TEXA

**ONE SCAN TOOL
TO RULE THEM ALL**



MED/HD TRUCK



CAR



POWERSPORTS



OFF-HIGHWAY



MARINE INBOARD
MARINE OUTBOARD

TEXA is the only company in the world that offers quality diagnostics for all commercial vehicles, passenger cars, exotic cars, off-road equipment, motorcycles, powersports and boats.

TEXA offers advanced capabilities for each diagnostic module, from DTCs to bi-directionals, resets and ADAS calibrations. The TEXA IDC5 software also includes technical information like troubleshooting, wiring diagrams and detailed repair procedures.

**THE TEXA TABLET
GOT EVEN BETTER**



AXONE NEMO 2

TEXA presents the new AXONE NEMO 2 proprietary tablet made to military standards (MIL-STD 810). The award-winning diagnostic solution is now rocking an upgraded Bluetooth module, a 12-inch Gorilla Glass screen, a robust magnesium casing and a new internal processor for unparalleled performance.

For more information visit VehicleServicePros.com/10094929



TEXA USA Inc.
409 Joyce Kilmer Avenue
New Brunswick, NJ 08901
www.texausa.com
northamerica@texa.com
+1 855.200.8392



**LAUNCH
TECH USA**

CREATE • CHANGE

MAKING SMART ADAS CALIBRATION EVEN SMARTER

PORTABLE

FOLDABLE

AFFORDABLE

X-431 ADAS Mobile

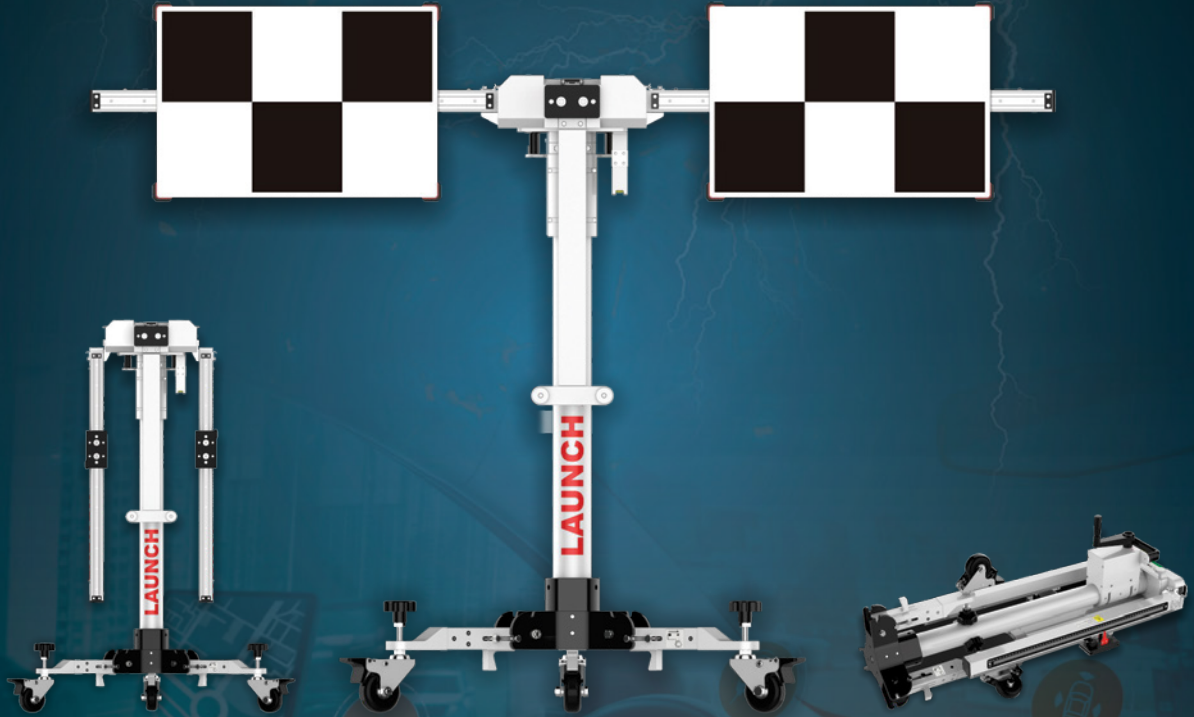

LDW



RCW



AVM



NV

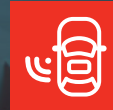

BSD

SMALL PANELS ★ AUTOMATED DESIGN ★ INTUITIVE INTERFACE ★ OE-LEVEL ACCURACY

LAUNCH

www.launchtechusa.com

1-877-528-6249



@LaunchTechUSA

For more information visit VehicleServicePros.com/10094390

DIAGNOSTIC PROCESS

Why shops need a diagnostic process

Using a standardized process can improve the efficiency and accuracy of vehicle diagnosis.

by David Brierley, Editor, *Fleet Maintenance* magazine

Repair work on any vehicle - whether it is a motorcycle, a passenger car, or a heavy duty truck - necessitates one common practice: diagnostics. In order to fix the vehicle, a technician must first know what the problem is that needs fixing. Over the years, shops have adopted more advanced diagnostic technologies as they have become available. But even the most advanced technologies cannot ensure a shop's success unless a standardized diagnostic process is implemented.

WITHOUT A PROCESS

Think about what your shop's current diagnostic process looks like. Many will start by immediately relying on the technology and hooking up a scan tool to see what codes the vehicle is reporting. Scan tools are an important part of the diagnostic process, but not necessarily the correct first step. By neglecting to first take actions such as replicating the driver's concerns with the driver present, a technician runs the risk of giving the vehicle back without all issues resolved, leading to a come-back or, worse, an exacerbated issue.

Using this more hodge-podge, case-by-case approach can actually slow the diagnostic process down. Starting by looking at what the technician *thinks* the problem is can lead them away from the actual issue, causing them to waste time trying to fix a symptom rather than the cause of the issue itself.

WITH A PROCESS

Setting up a standardized diagnostic process can be beneficial to everyone involved. For technicians, having a set of steps to follow for each vehicle that enters the bay means they can think less about what to do next and concentrate more on finding the issue. This can allow them to get to the root cause of the issue faster without having to trace it back, saving valuable time. It also allows the technician to be more thorough in their investigation of the problem, decreasing the likelihood of a come-back or unresolved vehicle problem.

For shop management, it means technician training can be streamlined down to the standardized diagnostic process as opposed to a different technique for diagnosing each type of problem. It can also mean a more efficient shop and fewer come-backs, leading to increased driver or customer satisfaction. For customer-facing shops, having a standardized process can also help management set pricing for both vehicle diagnostics and repairs.

In the following pages, we will look in greater detail at the importance of using a diagnostic process and specifics on how to get started setting one up; remote diagnostics and how this new technology can help fleets get a jump start on vehicle repairs; the specifics of what a proper diagnostic process should include; getting the most out of your scan tool; and connecting with customers. Plus, you will find details on the latest products that can help your shop efficiently diagnose vehicle issues. 



6 How to establish a step-by-step diagnostic process

Implementing a formal process not only improves consistency in the shop, but offers many benefits to clients as well.

8 Data from a distance

Remote diagnostics provides fleets with actionable intelligence on vehicle system status even before the vehicle pulls into a service station.

12 Developing a diagnostic game plan

To be successful today and in the future, you must understand a vehicle's systems and components.

15 Tips for maximizing scan tool use

The scan tool provides a window into what the electronic control unit is seeing. Here are some tips on maximizing your scan tool use.

18 Beyond the repair

Leverage scan tool documentation and features to connect with customers.

20 Diagnostic products

THE ABILITY TO SERVICE JUST ABOUT ANYTHING

PRO-LINK® Edge

- New PRO-LINK® Edge Software Upgrades
- New Cummins® Engines v4.0:
 - Years: 1994-2021
 - Supports EPA '07, '10, '13, '17, pre-EPA '07, and natural gas engines
- Detroit Diesel® Suite (DDEC® 6, 10, 13, 16) v.3.0
 - Years: 2007-2021
 - Supports Series 60™, DD5™, DD8™, DD13™, DD15™, DD16™, and MBE

BRENNAN PRICE
Heavy-Duty Technician
Klink Equipment
Freedom, WI



Snap-on®

For more information visit VehicleServicePros.com/10095583

Talk to your Snap-on representative about available configurations including a cart with 27" touchscreen monitor, software and adapters.



How to establish a step-by-step diagnostic process

Implementing a formal process not only improves consistency in the shop but offers many benefits to clients as well.

by Barry Hoyland, Contributing Editor

Most technicians think the beginning of a diagnostic process involves breaking out the scan tool, but that's not always the case. In order to build a good diagnostic strategy that will work on every vehicle with any type of problem that comes into the shop, you will need to create a process that includes using the right tools, and also one that incorporates obtaining relevant information.

A good diagnostic process will:

- Improve profits
- Create more consistency from all technicians
- Make it easier to explain to your client why you are charging for diagnosis
- Reduce come backs
- Mis-diagnose fewer vehicles

I have numerous examples throughout my many years in this industry of why a process is beneficial, but I will give you a few that stick out and have made a significant impact as to how we approach any diagnostic process in our shop.

EXAMPLE 1 – ALWAYS DUPLICATE THE CUSTOMER'S CONCERN

Many years ago, I had a customer bring in a Pontiac that she stated stalled when coming to a stop. She left the vehicle with us along with the spare keys. We checked the vehicle over and found it had a very rough idle. The tune-up parts were okay, but the carburetor mixture could not be adjusted to clear up the rough idle. We

recommended a carburetor overhaul, after which the car drove fine.

The next day after the customer picked up the car, she called and stated she had the same problem when she went to work that day. We thought that we may need to adjust the choke, so we had her bring it back in and leave it overnight. The next day, we made a minor adjustment and didn't experience the issue.

The customer picked up the vehicle and was gone no longer than five minutes when she returned again to complain about the car stalling. This is when I decided to go for a ride with her. The first thing I noticed when I got in the passenger side was that she had exchanged the key ring she left us, which only had two keys on it, with one that had a long tether with at least 20 keys and gadgets on it.

She left the lot and, as I expected, the weight of all those keys swung forward when she stopped and shut off the ignition. After that moment we made sure that step one of *every* diagnosis is to duplicate the customer's concern, even if they need to drive the car.

Hand in hand with duplicating the problem is asking enough of the right questions to make sure you have enough information to duplicate the issue.

We had another customer that complained of a noise when driving on the freeway. We drove the car and found no unusual noises. We asked the driver to take us for a ride and found that when the car was driven at approximately 75 mph (15 mph over our speed limit) there

was a wind noise that occurred, which turned out to be air crossing over the roof rack. Since we don't drive vehicles over the speed limit, we were unable to duplicate the noise.

EXAMPLE 2 – ALWAYS CHECK THE BASICS

I had a very good diagnostic technician that I relied on to perform most of our emissions and drivability issues. In almost every case, he would diagnose the issue quickly and correctly, but one day he made an error which highlighted some missteps in our diagnostic routine. In short, we did not have a process where every technician used the same steps on every vehicle and followed a set of tests that checked all of the basic mechanical and electrical standards each vehicle must meet.

Every vehicle needs a good battery and charging system in order for all the electrical components to function. Every vehicle needs a mechanically sound engine in order for the computer to function properly. If the engine's mechanical functions are compromised in any way, the computer can't do anything to correct it.

My technician made a very common error: he didn't check the basics at the beginning of his process. In this case, my technician was tasked with diagnosing a check engine light. This car, a Mustang, had a code for a faulty manifold absolute pressure (MAP) sensor. My technician replaced the sensor, then came to me stating that the new sensor was defective

Diagnostic Worksheet Stage 1

Original Concern: _____

Customer: _____	Date: _____	RO: _____	Tech: _____	Scan Tool Used _____
Model: _____	Make _____	Year: _____	Engine: _____	Mileage In: _____ Mileage Out: _____

Underhood

Oil Level: OK ___ Low ___ Over ___ Oil Added: Y N Last Service Mileage _____ Coolant Level: OK ___ Added Amount _____
 Oil Condition: Good ___ Poor ___ Service Due: Y N Belt Cond: OK ___ Needs Attn ___ Coolant Condition: OK ___ Needs Attn ___
 Charge System: Volts ___ Amp ___ Battery Volts ___ Connections: OK ___ Needs Attn ___ Hose Condition: OK ___ Needs Attn ___
 Notes: _____

Diagnostic Tests/Results

Engine Light: On ___ Off ___ Idle Qual: Neut OK ___ Poor ___ In Gear OK ___ Poor ___ Codes: _____
 Misfire Present: Y ___ N ___ Monitors: All Complete ___ Incomplete: _____ Pending Codes: _____
 Freeze Frame: (List Codes) _____

Scan Data

Coolant Temp: _____ B1S1 MV _____ B1S2 MV _____ B1S1 Rise Time in MS _____ OK: Y ___ N ___
 MAP _____ MAF _____ B2S1 MV _____ B2S2 MV _____ B2S1 Rise Time in MS _____ OK: Y ___ N ___
 Idle Speed N _____ In Gear _____ B1 STFT _____ B1 LTFT _____ Combined _____ Distance Since Codes Cleared _____
 TPS/APP Voltage _____ B2 STFT _____ B2 LTFT _____ Combined _____ Misfire Count/Cyls _____
 Loop Status: Open ___ Closed ___ Baro _____ Ref Volt _____ IAT _____

Recommendations

Customer Concern Duplicated: Y ___ N ___ If Yes List Road Test Conditions: _____
 TSB's Related _____
 Findings/Recommendations: _____
 Additional Tests Required: Mechanical Functional Tests (Stage 2) _____

Creating a worksheet like this one will help technicians document the results of their tests and provide you and the customer with information that can help in explaining what is "good" and "bad" with the vehicle.

and needed another one. Being as this technician was right much more than he was wrong, we ordered another sensor. When the new sensor came, he installed it then came to me saying the car needed a new powertrain control module (PCM).

This is where I stopped him. We have replaced very few computers because we have found computers to be extremely reliable and, in most cases, issues are caused by other factors. I followed the technician to the car where I was going to confirm the need of the PCM. As I was walking by the rear of the car, I noticed a "popping" sound coming from the exhaust. I asked the technician if he had checked engine vacuum with a vacuum gauge. He said he hadn't and just assumed it was okay. We installed a vacuum gauge on the manifold and saw that the vacuum was jumping between 15 to 25 inches of vacuum, indicating a broken valve spring.

A MAP sensor reads engine vacuum and reports it to the PCM. Since the vacuum reading was fluctuating so much, the computer assumed the sensor was faulty and set a code.

As soon as I returned to my office, I sat down and wrote a complete diagnostic process, which included duplicating the customer's concern and checking the basics like engine vacuum and battery voltage.

I have since evolved our diagnostic strategy to include a three-stage process. Stage one is a system check, including the basics. Stage two is a little more involved with performing some intrusive tests when necessary, such as compression testing or timing belt alignment. If the diagnosis is not clear after stage one and two, a stage three is required where you would perform specific pier to pier or pinpoint tests from the computer to individual components.

By using this approach, we have found it much easier to set a price and explain to the customer what we are doing and provide the results of a diagnostic test to them. Another good reason for a detailed process is that every technician can be trained to perform the process so that every vehicle is tested in the same manner.

These examples help to explain why a diagnostic process is necessary. In order to implement this process in your shop, first meet with your technicians and ask them how they approach a diagnostic problem. Document these steps, then meet again with your technicians to make sure they are on board with the new, formal process. Once your shop's technicians are on board, create a worksheet that must be completed as they diagnose vehicles. Documenting the results of their tests will provide you and the customer with information that can be useful in not only diagnosing the issue, but it will help in explaining what is "good" and "bad" with the vehicle.

The good and bad can assist you in charging a reasonable fee for your diagnosis, and quite possibly help you sell additional services.

Understanding why you need to develop a process, and following through with implementing it with your technicians, will pay dividends almost immediately by improving the quality of your diagnostic test procedures. 

Data from a distance

Remote diagnostics provides fleets with actionable intelligence on vehicle system status even before the vehicle pulls into a service station.

by Tyler Fussner, Assistant Editor

Remote diagnostics offers fleets the capability to monitor a vehicle in real time as it is on the road. Fault codes, along with other vehicle information, can be recorded and transmitted to the appropriate parties in order to inform fleet managers, maintenance managers, and technicians of vehicle data, status, and events. With diagnostic information being transmitted in real time, fleets can work in tandem with remote diagnostics providers to decide the best course of action for that vehicle and, in turn, expedite the diagnostic process before the vehicle pulls into the bay.

ACCESS TO REAL-TIME DATA

“In its simplest form, remote diagnostics means having the ability to receive real-time diagnostic data from the vehicle without being in its vicinity,” says Scott Bolt, vice president of product management, Noregon. “Effective remote diagnostics give the user the tools to diagnose the truck rather than a stream of SAE fault data. Remote diagnostic applications should describe the vehicle’s state in simple terms and provide actionable plans because there is a far greater chance the user does not have a comprehensive maintenance background compared to those using in-shop tools.”

Bolt adds that remote diagnostic tools should offer enhanced OE-level fault codes, effect-on-vehicle descriptions, action plans for managing the vehicle based on its current state, and bidirectional tools to correct problems and avoid costly tow jobs or mobile repairs that lead



shotbydave/Getty Images

to avoidable downtime.

In order to effectively diagnose a vehicle remotely, sufficient data and information must be provided across all accessible systems on the vehicle.

“The information that is programmed can be extracted,” says Bruno Gattamorta, vice president of sales and marketing, Cojali USA. “Since there are thousands and thousands of data inputs, you can program the most relevant and then extract the rest at a later time. Anything that goes on the CAN lines or is governed by an ECM can be extracted, and in our case, modified.”

The live data, load capacity, consumption, speed, throttle level, and more can be monitored, Gattamorta says. If the truck measures it, it can be extracted via telematics.

Beyond monitoring systems and diagnosing issues, a remote diagnostics integration can also help fleets manage operations. Insight into vehicle performance provided through a remote diagnostic and telematic solution can lead to

improving safety, decreasing liability, and optimizing fuel economy, Bolt says.

Remote diagnostic systems come in many shapes and sizes, from OE integrations to aftermarket options. Understanding what different remote diagnostic systems have to offer and how they provide such offerings can help fleets navigate the decision-making process of how to best implement remote diagnostics into their operations and which option is best suited for their needs.

One example of an OE remote diagnostic solution is Mack Trucks’ Mack GuardDog Connect.

“Mack GuardDog Connect hardware is comprised of our proprietary telematics gateway and hundreds of sensors located throughout the truck working together to monitor data from each truck for fault codes that are triggered when something goes wrong with one of a vehicle’s major systems, such as the engine or transmission,” says David Pardue, vice president of connected vehicle and contract services, Mack Trucks. “The gateway is ↻

THE RIGHT TOOL. WITH THE RIGHT SUPPORT. FOR THE RIGHT FIX. RIGHT AWAY.

Driven by Intelligent Diagnostics from Snap-on®, the **APOLLO-D9** provides all the information, resources and support you need—including filtered codes and vehicle-specific data—to help you find the right fix fast.

Everything you need, and nothing you don't. For *that* specific issue on *that* specific vehicle. With a host of features and advantages you'd otherwise expect only from a more advanced diagnostic tool.

Bring greater focus to every repair—and greater efficiency to the shop. Ask your Snap-on Franchisee for a demo today.



Intelligent Diagnostics from Snap-on.
Available on the APOLLO-D9, TRITON-D9™ and ZEUS™.

For more information visit VehicleServicePros.com/10095583

Smarter. Faster. Fixed.

Snap-on



TM

Snap-on is a trademark of Snap-on Incorporated. All rights reserved. ©Snap-on Incorporated 2020.



REMOTE DIAGNOSTICS

designed to access the core data networks within the trucks in order to reliably collect and store data without interfering with truck operations. The sensors collect streaming IoT data, including where a particular mechanical event happened and what conditions were present during the fault, such as altitude, ambient air temperature, rpm level, and torque load to give the information context for diagnosis.”

Having a vehicle manufacturer offer a remote diagnostic integration brings with it the advantage of total system understanding and simplifies the decision-making process when choosing a provider for fleets that run one manufacturer type.

“Mack uses software from SAS to apply complex and analytical-based rules,” Pardue continues. “If an issue is detected, the software creates support cases and sends them to an outbound message queue. Mack uses the ASIST system, a web-based service management platform, to pick up messages from that outbound message queue to process customer notifications. Customers are then notified of faults by a Mack Trucks Uptime Center employee based on their preference for email, text, and/or phone notifications.”

INFORMATION DISSEMINATION

The way in which the information gathered from remote diagnostic systems is relayed and displayed is just as crucial as the information itself. Presentation is everything, and the ability to tailor that data to the needs of a fleet operation can make all the difference in successful utilization of remote diagnostics.

“Remote diagnostic software is typically a web portal or mobile application,” Noregon’s Bolt says. “The portal should offer high-level information from a dashboard view so the total health of a fleet can quickly be discerned in a glance, but offer advanced capabilities to drill into issues on individual vehicles to pass along to

maintenance professionals.”

“There is a fine line between overwhelming the user with too much data and not offering enough information to make actionable decisions,” Bolt advises. “This signifies the importance of a customizable system that the fleet can configure to their needs ... One of the great aspects of remote diagnostics is managing who receives which bits of information. For example, a maintenance manager can be set up to receive comprehensive diagnostic information when trucks reach a certain severity level, while dispatchers are made aware of actionable faults, which are faults that the driver can address through actions such as adding coolant.”

Remote diagnostics systems such as Noregon’s TripVision Uptime offer fleets the flexibility to be alerted to certain parameters of their choosing, such as when a truck registers a fault code that affects fuel economy, Bolt explains. These parameters can be fine-tuned according to a fleet’s operation across all vehicles, or to specific vehicles and routes.

“For Jaltest Telematics, what you get is a user portal where you can filter by vehicles, features, and functionalities,” Cojali’s Gattamorta says. “The goal is to have a holistic approach with insights from customers [on pick up and deliveries], from the technicians [based on maintenance data], and the fleet manager [via geofence, driver behavior, GPS tracking, et cetera]. When you enter the platform, you can use one vehicle or run driver behavior comparisons, load distinction, harsh braking metrics, et cetera. Guiding drivers through their metrics gives great insight on consumption.”

ACTIONABLE INSIGHT

When a fleet decides which information is most pertinent to their operations, and the manner in which they prefer its delivery, the next determination is how this remote diagnostic information can be best utilized to maximize uptime and improve

operational efficiencies.”

“After identifying an issue, Mack GuardDog Connect has the ability to let customers know if it’s a critical fault that could potentially shut a truck down, or if it’s something more minor that can be addressed at a later date,” Mack Trucks’ Pardue says. “In addition, the system does confirm parts availability, as well as dealer service by space, all while the customer’s truck is still on the road.”

Bolt relays that Noregon considered users of remote diagnostic tools may not have extensive maintenance backgrounds, and so designed TripVision Uptime to “feel like there is a master mechanic monitoring all of your trucks.” When an issue is detected, information presented as “action plans” is delivered and explains the best way to handle the truck in its current state. This could be notifications to pull over before extensive damage occurs or coordinating diagnostic information with a shop to initiate a triage before the vehicle arrives on site.

“One of the latest technologies we added to TripVision Uptime is predictive health,” Bolt says. “We can alert users [to conditions] that are likely to escalate into a serious problem, give time and mileage estimates for when the failure would occur, as well as the relative likelihood that the failure will happen. With this information, customers can schedule maintenance for an issue that has not yet occurred but could lead to a breakdown or more costly repair if not addressed.”

Remote diagnostics are the forefront of total insight into operations and performance. Fleets have the ability to integrate such systems into their vehicles in order to capture real-time data without having an asset parked in a service bay. Utilizing the insightful data provided through remote diagnostics offers the ability for fleets to stay ahead of impending failures, accurately and timely unveil performance issues, and furthermore optimize efficiencies and uptime. ●

A TOOL FOR EVERY TECH!

MAXIMUS 3.0

ALL THE INFORMATION YOU NEED TO GET THE JOB DONE.

- Innovative features and intuitive design
- Wide coverage and capabilities
- Time saving technology



MAXFLEX

1 TOOL. 3 WAYS TO FLEX.

- Enhanced code reader/tablet
- Full coverage with annual updates
- Customized monthly subscription



MAXLITE

MINI AND MIGHTY DIAGNOSTICS.

- Maximus diagnostics on a small scale
- Flexible and affordable
- Light and portable



For more information visit VehicleServicePros.com/10095267

Talk to your Matco Tools Distributor or visit www.matcotools.com for more information.



Developing a diagnostic game plan

To be successful today and in the future, you must understand a vehicle's systems and components.

by **Brandon Steckler, Contributing Editor**

We've all heard the saying "knowledge is power," but knowledge can be quite profitable, too. A rock-solid technician is one that has honed their craft as being a problem-solver. We often think of that person as one who can "fix" anything. Although that may be true, there is certainly more to it than being good with your hands. Having an understanding of the systems and the components vehicles are comprised of, along with the goals of each, is what it takes to be successful in today's world of automotive service, repair, and especially diagnosis. Learning to leverage service information in your diagnostic approach can yield efficiency and success.

While it may seem counter-intuitive to step back and tread slowly (especially from a "flat-rate" perspective), separating oneself from the vehicle, creating a game-plan, and seeing it through will keep you focused on the facts. This, in turn, will create efficiency without missing any steps. When I approach a vehicle, I never do so without having a game plan. For me, this means gathering pertinent data about the components that make up the system. I look to address:

- How are the components configured to carry out a goal?
- What is that goal?
- How do we know whether the goal was achieved/how is the system monitored?
- What are some parameter IDs (PIDs) that can give me easy-to-grab insight into the system's functionality?

These items can yield plenty of preliminary information about any problem, on any system, in any vehicle. Think for a moment how powerful of a statement that is. Regardless of what is in your bay, it's this information that will allow you to efficiently solve the riddle. Think of the game plan as nothing more than a series of questions. I invest my time away from the vehicle developing the questions I wish to ask the vehicle. The tools I use and the tests I perform will carry out the questioning process. The results of those tests are the answers I need to make the necessary diagnostic decisions.

CALLING THE HUDDLE

I spend my initial diagnostic time understanding the preliminary information. This key information can be found in the service information. Many of us rely on aftermarket sources like ALLDATA, Mitchell 1, Identifix, MotoLogic, etc. Some of us purchase access to OE service information. When it comes to answering the age-old question, "Which source of information is the best?", the answer is simply *all* information is the best.

TROUBLESHOOTING FLOWCHARTS – ARE THEY OF VALUE?

I recall at one point in my career being let down by troubleshooting flowcharts. I was confident that any issue could be solved so long as the flowcharts were followed. To my dismay, many times I was left with the only option to substitute a known-good component (like a powertrain control module [PCM] ... I'm sure we've all been down those winding roads a few times).

I recall being discouraged by the fact that not only was the vehicle's ailment still present, but I had invested a lot of time and money and was no further along than I was hours ago. How could this have happened? What was the missing element that prevented me from being successful? After all, the flowcharts were written to help me fix the vehicle by the same people that designed the vehicle, right?

Wrong. The flowcharts are there to help the average factory-trained technician repair a vehicle (that's under warranty) in the most financially efficient way the majority of the time. The flowcharts are written concerning the most likely failures the system(s) might encounter. They are not written concerning our wallets. This is why we may spend so much time with disassembly/reassembly rather than a pursuit with logic. Of course, we realize that the engineers who design the flowcharts aren't necessarily the same engineers who design the systems. There tends to be a disconnect between the two.

Over the years I've learned that there is key information within those flowcharts that I use every day to streamline my diagnostic approach. Reading the steps and following them blindly is never recommended. Understanding what each of the steps is asking for will give you a good idea of what the electronic control unit (ECU) is looking for and anticipating, as well as a logical approach. One example is resistance specifications – keeping in mind that voltage drop, resistance, and current flow all relate to one another. Knowing what the resistance specification is calling for will allow us to anticipate how much current flow the circuit being

monitored should draw. This is how circuits are being evaluated for performance and the reason why related diagnostic trouble codes (DTCs) are set when components' ohmic values fall too far outside of specification. I'd much rather monitor a circuit's current flow dynamically than to open the circuit and measure for resistance statically. A comparator circuit is used to carry out this task for the ECU's self-diagnostic strategy (Fig. 1). It serves

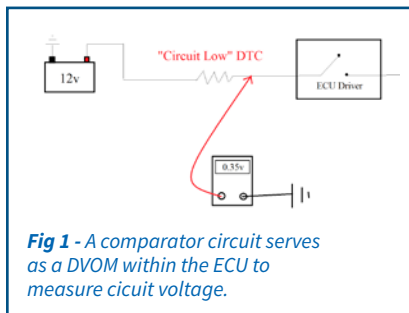

Fig 1 - A comparator circuit serves as a DVOM within the ECU to measure circuit voltage.

as a DVOM within the ECU to measure voltage in the circuit under various states of operation. In the example drawn here, a few things can be seen:

- The circuit is of a pull-down design (ECU provides the ground-path to energize the circuit).
- The circuit is open, and no current should be flowing.
- The DVOM should be measuring/indicating source-voltage (12V) in the circuit's current state of operation.

This is what is typically occurring when an ECU sets a DTC about "circuit-low" faults.

THE BASIC BUILDING BLOCKS OF DIAGNOSTICS

Viewing not only the wiring diagram but also the theory and operation of the circuit provides for a solid understanding of the circuit functionality and anticipation of what the ECU expects to see on that circuit during its current state of operation (energized or de-energized circuit). The DVOM represents not only where the ECU is monitoring the circuit, but

also where we would place our DVOM to monitor the circuit ourselves. In the example in Fig. 1, it should be obvious that the intended state of the circuit would have us anticipate source-voltage at that point under the circuit's current state of operation. A lot can be derived from just these few pieces of data.

Remember: Having fundamental knowledge of the individual components' functionality (at the most basic level) can be applied to any vehicle or system out there. Nearly 85 percent of what occurs in any automotive circuit can apply to any vehicle or system. This is due to the physics involved. The remaining 15 percent is how each manufacturer chose to make that circuit function. Combining basic fundamental concepts (from years of practice) along with the tools and testing techniques you've learned to employ can help yield a diagnosis efficiently.

A SHIFT IN STRATEGY

To demonstrate this process, I will use an example: A 2008 Dodge Grand Caravan experiencing a stored DTC P0760 "over-drive-solenoid circuit fault," along with a transmission functioning in a defaulted state (no upshift from second gear). The point isn't necessarily that the vehicle was fixed, but more so how the circuit is being monitored and what techniques I recruited from my experience and fundamental knowledge to prove the fault and repair the vehicle.

I built my game plan away from the vehicle by referencing the service information for DTC P0760. The description and operation of the system and the wiring diagram proved to be all I needed in my arsenal to approach the vehicle and ask of it the questions I would like answered.

- Why won't this vehicle upshift?
- Why is the DTC set?
- Is the solenoid functional?
- Does the solenoid have everything it needs to function?

The ECU was anticipating seeing an inductive kick. To have a healthy functioning solenoid, the resulting inductive kick from its magnetic field collapsing should be present. Said another way: If a weak inductive kick is present, the solenoid cannot do its job properly.

The service information and wiring diagram together tell us where to test, how the circuit functions, what we should anticipate seeing during a test, and what the ECU is looking for to either verify or condemn the circuit for functionality.

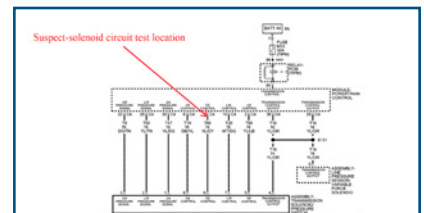

Fig 2 - By placing a lab scope at the point indicated on the wiring diagram and referencing it to ground, we can compare the signature to that derived from testing one of the known-good solenoids, controlled by the PCM.

(Fig. 2) By placing a lab scope at the point indicated on the wiring diagram and referencing it to ground, we could then compare the signature to that derived from testing one of the known-good solenoids, controlled by the PCM.

The PCM was located within the left-front fender well of the vehicle (Fig. 3). The appropriate connector and circuits were identified and then probed to be monitored while using the scan tool to carry out a bidirectional control of the individual solenoids. The test results ➡

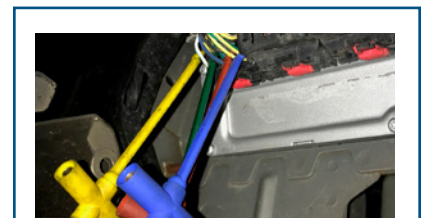

Fig 3 - The PCM was located within the left-front fender well of the vehicle (shown here).

Photo credit: B. Steckler

SMARTER DIAGNOSTICS

STARTS
HERE



AUTEL MAXISYS
MS909

MAXIFLASH VCI NEW PROTOCOLS

- OR -



AUTEL MAXISYS
MS919

MAXIFLASH VCI FIVE-IN-ONE VCI

— BOTH TABLETS FEATURE —

INTELLIGENT DIAGNOSTICS

- REPAIR ASSIST
- GUIDED DIAGNOSTICS

TOPOLOGY MODULE MAP

- ALL SYSTEM STATUS SCREEN
- COLOR CODED FAULTS

POWERFUL HARDWARE

- OCTA-CORE PROCESSOR
- 128GB MEMORY



AUTEL.COM/ULTRA | 855.288.3587

@AUTELTOOLS

©2020 AUTEL U.S. INC., ALL RIGHTS RESERVED

AVAILABLE NOW! CONTACT YOUR LOCAL DISTRIBUTOR

For more information visit
VehicleServicePros.com/10095724



RELATED PRODUCTS

Cojali

Jaltest Info Online
For more information visit
VehicleServicePros.com/21075591

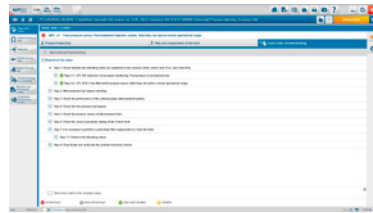

Mitchell 1

ProDemand Interactive
Wiring Diagrams
For more information visit
VehicleServicePros.com/21131406

Pico Technology

PicoScope, Nos. 4425A and 4225A
For more information visit
VehicleServicePros.com/21139759



proved that the suspect solenoid circuit did not produce a healthy inductive kick like that of a healthy solenoid circuit. It also displayed that the ground side of the circuit was compromised and the PCM was likely at fault. This conclusion was made because the ground path still had significant voltage available on it when energized. That, coupled with the fact that we tested directly at the PCM terminal, concluded that wiring was not an issue. If the PCM's ground was compromised, the other solenoids' circuits would've suffered as well.

The only logical explanation was a poorly functioning solenoid driver within the PCM itself. To further prove the fault, I continued to monitor the suspect circuit. This time, I supplied an external ground which allowed me to bypass the PCM. This enabled the solenoid to function properly and resulted in a voltage signature that pulled very close to the ground and an inductive kick, similar to the known-good solenoid when the circuit was de-energized. I followed the above test with a measure for current flow from each of the solenoids using the lab scope and a low-amp probe. Seeing

that they all drew about the same amperage reassured me that the failed PCM driver had nothing to do with a shorted solenoid-winding.

Being an efficient and accurate diagnostician isn't about having the fastest hands in the shop. It's more about using logic. Having fundamental knowledge built from mastering the basics and learning to utilize the tools you have comes from practicing on known-good vehicles and investing your free time to better yourself. Take time away from the vehicle to develop a diagnostic game plan derived from the goodies provided by service information. A combination of the wiring diagram and description/operation will yield you the arsenal you need to combat the vehicle and win the battle. It all starts with a little discipline and patience, but it ends with the rewarding feeling of a job well-done. 🍀



Brandon Steckler is Technical Editor of *Motor Age*. He is a working technician at Lykon Automotive in Bristol, Pennsylvania. He has worked in the field for over 18 years and holds multiple ASE certifications.

Tips for maximizing scan tool use

The scan tool provides a window into what the electronic control unit is seeing. Here are some tips on maximizing your scan tool use.

by **Brandon Steckler, Contributing Editor**

Every journey begins with one single step. Some people take that step with their left foot and others with their right. Neither would be considered incorrect. One journey can be carried out a number of different ways. The point is, there is no correct or incorrect way to get to a destination, so long as you get there.

The same holds true regarding diagnostics, or more specifically, analysis. We can pursue a symptom from multiple angles. Some technicians have a well-developed seat-of-the-pants, instinctive-feel (probably developed from years of getting their butts kicked in the trenches of the automotive industry) and can be fairly accurate in their diagnoses. Other times, those same technicians make costly mistakes because no true testing was carried out. Some technicians begin and end their analysis with the scan tool and follow their instincts from there. They employ subsequent tests that focus more on a particular area of a system, perhaps giving them the ability to decide what can't be the source of the fault. This limits the amount of guessing.

The truth is, if you are not testing, you are indeed guessing. The scan tool provides us with a necessary and time-saving preliminary step. The information from the scan tool does more than display diagnostic trouble codes (DTCs). It can also show us what the electronic control unit (ECU) believes it sees, as well as its intent, or how it decides to control the components for the systems it's in charge of. Following are some techniques I use to decide where I want to invest my allotted diagnostic time.



THE ENTIRE STORY

Let's start with parameter IDs (PIDs). The PIDs a technician views will depend on a few variables – the first being your scan tool of choice. Many of the PIDs found in the OBD generic portion of our scan tool exist because they are mandated to be there by law. Many times, we must view information that is more vehicle-specific, meaning we may have to view it from the enhanced side of the powertrain control module. Not all scan tools are built the same. If they were, we would have an extremely expensive device that could communicate with every node (ECU) on the network, and support every PID, as well as every bidirectional control. This is certainly not the case. I have a few scan tools I employ regularly. I find where one of them falls short, the other can fill in the gap.

Another variable is the loop-speed, or the speed in which the scan tool can refresh. When we select to view a set of PIDs, we are making an inquiry to the ECU for each PID we select. The ECU will have to process the request from the scan tool and then reference the inputs

it's processing from the vehicle. It will then report the data to the scan tool, where it's processed and delivered to us for viewing. All of this takes time – the more inquiries we make, the slower the scan tool performs ... so choose wisely.

Next, consider the vehicle system you are addressing. Some systems are simple and may involve one or two ECUs to carry out the process of opening and closing them. Other systems are very interdependent upon one another (like ADAS, traction control, or even HVAC) and require communication between several ECUs and many times over multiple communication networks. I'm always looking for the scan tool to tell the entire story. I should be able to capture the inputs to the ECU, as well as the outputs to reflect what the ECU sees and if the ECU is trying to generate an output. The data should be collected in a fashion that a fellow technician could analyze the capture and make a diagnostic decision.

Last, but certainly not least, it helps to have a thorough understanding of the system and components that are being addressed. The ability to analyze scan

 **RELATED PRODUCTS**



CanDo International

HD Pro III
For more information visit
VehicleServicePros.com/21138072



Innova

FixAssist 5160RS
For more information visit
VehicleServicePros.com/21162148



TEXA USA

AXONE 2 Truck
For more information visit
VehicleServicePros.com/21151562



Topdon USA

ArtiPad
For more information visit
VehicleServicePros.com/21080235

data is just that. Without the understanding of system-configuration (all the players involved in carrying out a specific goal or output), there would be no understanding of which data PIDs were necessary to view. The decision about which of the PIDs to display will be derived from the information found by referencing a wiring diagram as well as the description and operation of the system. These PIDs will represent:

Inputs: Information about individual components' physical state (pressure, temperature, angle, or position) and the intent of the ECU or person operating the system.

Decision making: This information, or processed data, is reflected by the ECU PIDs and indicates a state of operation (a "thumbs-up" or "thumbs-down," if you will). They will typically be displayed as "on/off," "yes/no," "permitted/not-permitted," etc. This gives us, as technicians, valuable insight.

Shared data: Many systems exist on a virtual platform, meaning their functionality requires a communication bus (or several) with integrity. If data that is being processed in a specific node is then reflected in the PID list of another node, this is a good indicator that the data is

being shared over the network. This provides for a means to split the system into sections in which to troubleshoot. With a little common sense and knowledge of the previously researched system, a lot of unnecessary testing will be avoided.

Outputs: This is the result. Thinking in terms of a true "system," any breakdown in the above-mentioned will not allow for an output to occur. Seeing the entire story reflected in the scan tool list will show your intent to operate a system, the data required for an ECU to make a decision, and the final decision to operate or not to operate a component (and the reason why). Ask yourself, would you be thinking about testing a switched input (like a window switch) if the scan tool reflected a PID that showed the intent to lower the window?

One of the most valuable times to employ the scan tool is during drivability analysis. Just think of how situations can yield a "low-power" complaint. Inputs/processing/outputs ... it's the same for drivability. We typically reference the fuel trim values to reflect how well the engine is being fueled. This is the end result or feedback. When a vehicle fails to produce power, it's because the engine can't breathe properly, the air/fuel ratio

is incorrect, or the ignition timing is not as it should be (or it is inadequate). With a properly set up PID list (in a graphed format) and running the engine under different operating conditions, it's easy to determine the cause of the low-power complaint right from the driver's seat.

Considering all this data is gathered right from the driver's seat, I can't think of a more efficient way to begin a diagnostic approach.

For each vehicle that rolls into the bay, your scan tool can open your eyes to how all the players function together to carry out a goal. You get to see the entire story play out for you, so diagnostic direction can be gained before investing time in a specific area. Begin employing these capturing/analysis techniques on well-known vehicles and get comfortable with the functionality of your specific scan tool(s). Learn the ins and outs of it and what makes it special. You do that and watch how quickly productivity and confidence soar in the shop. 



Brandon Steckler is Technical Editor of *Motor Age*. He is a working technician at Lykon Automotive in Bristol, Pennsylvania. He has worked in the field for over 18 years and holds multiple ASE certifications.

THE FUTURE OF DIAGNOSTICS IS HERE

ULTRA



12.9" SCREEN / ANDROID 7

FIVE-IN-ONE VCMII

- OSCILLOSCOPE
- MULTIMETER
- NEW PROTOCOLS

TOPOLOGY MODULE MAP

- ALL SYSTEM STATUS SCREEN
- COLOR CODED FAULTS

INTELLIGENT DIAGNOSTICS

- REPAIR ASSIST
- GUIDED DIAGNOSTICS



MAXISYS MS919

- 9.7" SCREEN / ANDROID 7
- INTELLIGENT DIAGNOSTICS
- FIVE-IN-ONE VCMII



MAXISYS MS909

- 9.7" SCREEN / ANDROID 7
- INTELLIGENT DIAGNOSTICS
- NEW PROTOCOLS



Beyond the repair

Leverage scan tool documentation and features to connect with customers.

by Sara Scullin, Editor

Scan tools are a vital part of the diagnostic process, and these tools have come a long way in the past decade or so.

From simple maintenance procedures such as identifying codes and performing resets, to advanced programming and ADAS calibrations, the use of scan tools is not only recommended, but essential.

The features and functions available on today's scan tools don't stop at the vehicle diagnosis. Rather, scan tools and scan tool software now go a step further by logging data directly into a customer file and helping technicians provide very thorough – and revenue generating – service. They help to connect technicians with their customers, verify repairs, keep track of maintenance, and earn repeat business.

When weighing various scan tools to purchase and the associated ROI, it pays to look at vehicle coverage features and diagnostic functions ... of course; today's tools now offer functions like built-in TPMS, the ability to do J2534, key programming options, remote diagnostics, and ADAS. Even so, technicians should also consider features that help to document and share repair information with other technicians in the shop, as well as with their customers.

Here's a look at how documenting and reporting functionality can "close the loop" in a successful repair experience.

SHARING DETAILED INFORMATION

A number of diagnostic products offered today allow technicians to share diagnostic repair information with customers in an easy-to-understand format. For example, Launch Tech USA's X-431 professional diagnostic tool family (includes



ferrantraite/Getty Images

X-431 Turbo, X-431 Torque, and X-431 Throttle) feature a Vehicle Health Report function that allows for digital sharing with customers, as well as gives the shop and technician the ability to print a hard copy report for customers. Both pre-scan reports and post-scan reports are prepared for each repair.

Documentation such as this goes a long way to bring customers peace of mind with their vehicle.

"The reports bring all issues and concerns to light in easy to follow, summarized detail," says Rogers Thiamthat, director of North America at Launch Tech USA, regarding the company's Vehicle Health Reports.

Repair documentation helps customers understand their vehicle problems in an often "too technical" automotive repair world, Thiamthat says. He adds, this additional information can remove the notion on the customer's part of a "bait and switch" tactic – meaning what they originally thought was an issue versus what someone without a professional diagnostic tool says might be an issue.

NO ROCK LEFT UNTURNED

Sharing brief, easy-to-navigate details

regarding the repair process with customers may even uncover issues that were not initially identified.

Launch Tech's Thiamthat believes this lets customers make the best decision possible to solve any and all vehicle problems and avoid comebacks.

"There may be cases where customers might not opt to repair right away, even [after learning and understanding information presented in] the Vehicle Health Report," Thiamthat says. "[The report], however, at least keeps customers aware of known issues and they can be proactive in getting everything in order."

REACHING OUT ... WITHOUT SACRIFICING PRODUCTIVITY

One factor that often prevents businesses from going the extra mile to share detailed information with customers is the notion that it takes additional time and takes workers away from the primary task. However, that doesn't have to be the case.

Snap-on Diagnostics offers pre- and post-scan reports with their products. The information can be uploaded and shared close to real-time, without as much as a phone call.

The technician can share vehicle system reports and images via text or email, share pre-scan reports and images with customers to receive quick approvals for repair, and forward pre- and post-scan reports and images to insurance companies to confirm OEM repair requirements have been met. So not only does this practice not add more time, but it can save time on the back-end when integrated into a diagnostic process.

“When connected to Wi-Fi, you can automatically upload images, vehicle system reports, and pre- and post-scan reporting to the Snap-on Cloud,” says Dave Hall, director of North American sales, Snap-on Diagnostics. “Once [the information is] in the cloud, it can be accessed by a phone, tablet, or computer whenever the technician or customer needs them. The Snap-on Cloud works to make each job faster. Once connected by Wi-Fi, every image or pre- or post-scan vehicle system report is captured automatically.”

Hall says newly afforded features within diagnostic products on the market are all about improving information and workflow for the shop.

“Technicians can mark and order files, identify images as ‘known good’ or ‘known bad,’ tag files to make keyword search faster for future reference, and retrieve files by customer name, VIN, or sort by date, allowing for easy retrieval,” Hall says.



Snap-on Diagnostic's Apollo D9 scan tool is one of a number of Snap-on tools that let technicians share diagnostic repair information and intelligence with customers via uploaded images, pre- and post-scan reports, vehicle system reports, and more.

In addition, they can compare and share information with peers and share images with other shops and technicians for the best possible intelligence.

These services are a boon to customers, who can get immediate information from the shop and give approvals for work. The shop can also provide their customers with copies of both the pre- and post-scan report and any related images to be able to give them confidence in the shop and repairs carried out. They also can get a good understanding of the full health of their vehicle, any pending codes, or preventative maintenance work that may need to be carried out in order to keep their vehicle in full working order.

Thiamthat says features like Launch Tech's Vehicle Health Report bring important service issues to customers' attention. He says such reporting can

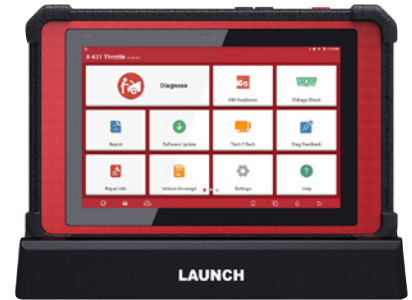

The Launch Tech USA X-431 Throttle diagnostic tool with charging base was developed based on the Android 7.1 system. It supports dual bands Wi-Fi communication (2.4GHz and 5GHz), and features wide vehicle model coverage, Vehicle Health Reports, and test data.

also make shops aware of issues or repairs they may not be equipped for.

Reporting features are a relationship builder, sealing the trust between shop and customer. “With this relationship comes lasting effects, such as repeat business, great reviews (which also drives more business), and referrals that provide feedback of a detailed, thorough, inciteful repair,” Thiamthat says. “We absolutely do not want to put a customer in a situation of being caught off guard on a preventable problem, or a high priority problem that needed immediate attention.”

So much of vehicle work nowadays is “invisible,” with issues vehicle owners may not see or feel. But today's top diagnostic tools offer features and capabilities to keep repair issues – and customers – out of the dark. 🚗

RELATED PRODUCTS



Bosch

3.8 Software Version
for ADS 325 and 625

For more information visit
VehicleServicePros.com/21091546



Autel

MaxiSYS ADAS
Calibration Tablet

For more information visit
VehicleServicePros.com/21037643



XToolUSA

Nitro XT Scan Tool

For more information visit
VehicleServicePros.com/21123808

COMES WITH OEM-APPROVED SMOKE-PRODUCING FLUID

The **OEMTOOLS EVAP/Smoke Diagnostic Leak Detector**, No. 24684, is designed to quickly find leaks on cars and light duty trucks. It locates EVAP leaks and cooling system leaks, identifies intake and exhaust leaks, and finds wind and water intrusion. The EVAP/Smoke Diagnostic Leak Detector features variable flow control and an integrated regulator. In addition, it comes with OEM-approved smoke-producing fluid.

For more information visit VehicleServicePros.com/21121810



CONTAINS EVERYTHING NEEDED TO MANAGE SCHOOL BUS FLEETS

The **NEXIQ Technologies Pocket HD School Bus Kit** has everything needed to manage school bus fleets with Cummins engines. In addition to the Pocket HD scan tool, the kit comes with the School Bus software suite, which includes HDS, LMT 2016, Cummins Lite, All Makes DPF Regen, Allison Lite, and the ABS brake suite. An array of Cummins special tests are part of the Cummins Lite software module (for example, DPF regeneration, DEF leak test, DEF doser pump override, reset DOC/DPF, and more). Also included are two adapters (a 9-pin and a 16-pin), a 26-pin data cable, and a soft carrying case.

For more information visit VehicleServicePros.com/21078554



FEATURES 12 FUNCTIONAL MODULES

The **ThinkTool** from **Thinkcar** is a modular design tool for automotive diagnosis and detection. It consists of a host machine and 12 functional modules. The host machine can be used alone or with any of the additional modules. Combined with any of the functional modules, ThinkTool is able to complete a wide variety of diagnostic scenarios. ThinkTool has support for more than 160 vehicle brands, with comprehensive and professional diagnostic functions. The 12 functional modules include a printer, printing paper, the base, working light, videoscope, thermal imager, battery tester, ThinkDiag box, TPMS, scope box, sensor detection, and projector.

For more information visit VehicleServicePros.com/21125260



OFFERS REMOTE SERVICES

The **DrivePro ES** from **Opus | IVS** is designed to give technicians the confidence to repair complex vehicles safely and fast with licensed OE diagnostic software, remote programming, and calibration while being connected to live repair guidance from OE master technicians. DrivePro ES is equipped with licensed OE diagnostic software to identify the root causes of issues for all major domestic, Asian, and European vehicle brands. The built-in remote assist program (RAP) offers hassle-free remote assisted flash programming to eliminate the uncertainty of programming complex vehicles by oneself. According to the company, the rugged tablet is easy to use and more affordable than buying software directly from OEMs.

For more information visit VehicleServicePros.com/21123836



ENHANCED BMW AND MERCEDES BENZ COVERAGE

The **AutoEnginuity Giotto Version 18.2** enhances 20MY coverage and improves enhanced BMW and Mercedes Benz coverage. Additions for BMW/Mini include added support to automatically discover and determine fitted modules for UDS vehicles and expanded coverage with over 200 UDS modules. For Chrysler, reset injector compensation values system test to PCM Var 19 has been added. Improved VIN retrieval for all late-model Ford vehicles, added lane change assist variant system for Boxster S '17, and added blindspot system monitor support for beam axis display and beam axis adjustment for Toyota/Lexus/Scion are also included in Giotto Version 18.2, among other additions.

For more information visit VehicleServicePros.com/21151617

OFFERS FLEXIBLE MOUNTING OPTIONS

The **Innovative Products of America Alpha MUTT with ABS and Rugged Tablet**, No. 5705A-RT, is a service truck edition that features real-time, wireless, diagnostic-troubleshooting software that allows service professionals access and control to all aspects of trailer service and repair with a military-grade, MIL-STD-810 certified, weather-proof tablet. The 5705A-RT's versatile design offers flexible mounting options: hang from a truck, cart, or wall. Users can test lighting, ABS and air brake circuits, and perform PMI and DOT inspections while walking around, or from inside, a vehicle.

For more information visit VehicleServicePros.com/21121151



ABLE TO VIEW HARD-TO-REACH AREAS

The **Launch Tech USA Videoscope 800** is designed for viewing and capturing hollow spaces and hard-to-reach areas in all types of vehicles. The videoscope features

a megapixel lens, 2.7" TFT display, and a lens tube of 1m in length and 5.5mm in width.

It allows the user to inspect the internal components of an engine for carbon deposits, wear and tear, and to pinpoint sources of unwanted noise. It also helps identify corrosion and confirms component failure without taking apart the entire engine block.

For more information visit VehicleServicePros.com/21129410

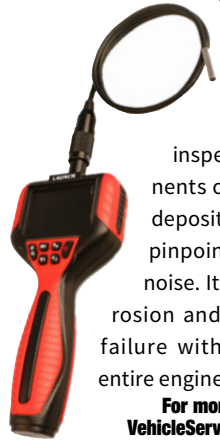

EXTENSIVE ADAS DATABASE

The **CAS Gscan-3 Scan Tool** multi-line, Android-based tablet scanner offers coverage for domestic, Asian, European, and commercial truck lines. Hyundai/KIA OEM software along with J-2534 reprogramming make this general-purpose scan tool a cost-effective alternative to purchasing the Hyundai/KIA factory tools, says the company. In addition, it offers an extensive ADAS database of calibration procedures. According to the company, over 20,000 tracked and proven calibrations have been performed with the G-scan software. Reporting capabilities include Bluetooth and Wi-Fi communications to both portable and fixed location printers, as well as direct to vehicle owner email.

For more information visit VehicleServicePros.com/21124537

PRECONFIGURED WIRELESS AND WIRED CONNECTIONS

The **Bosch Mastertech II** is a J2534-1 and J2534-2 compliant VCI for OEM reprogramming and diagnostic applications. The Mastertech II has been fully validated to operate with top OEM reprogramming applications, including: GM, Ford, FCA, Nissan/Infiniti, Honda/Acura, and Toyota/Lexus. Supported by both 04.04 and 05.00 APIs, the product is designed to be compatible with future OE communications requirements. The preconfigured wireless and wired connections, including Wi-Fi, ethernet, and two USB-A connectors, make it quick and easy to connect to a vehicle from a PC.

For more information visit VehicleServicePros.com/21155354



Introducing the new

PicoScope[®]

EV KIT

The world's most complete EV testing solution

Visit www.picoauto.com/A724 to learn **MORE**

A collection of blue and yellow diagnostic tools including a multimeter, cables, and a PicoScope device, arranged on a white surface.

pico
Technology

Email: sales@picotech.com. Errors and omissions excepted. Please contact Pico Technology for the latest prices before ordering.

For more information visit VehicleServicePros.com/10094540



ACCEPTS ADDITIONAL HARDWARE TO EXPAND ITS FUNCTIONALITY

The **Injectronic CJ7S Diagnostic Kit** is designed to assist technicians with all automotive diagnostic scenarios by offering modules for scanners, oscilloscopes, battery testers, and extended interconnects. The CJ7S is an easy-to-operate, portable device that accepts additional hardware to expand its functionality. By allowing technicians to acquire modules, they don't have to continuously buy scanners that may duplicate or overlap in coverage, the company says. With the CJ7S, technicians are able to communicate with the vehicles in scan mode, capture signals from sensors and actuators in oscilloscope mode, and test batteries with conductance technology. It also features Wi-Fi and Bluetooth communication with Android devices.

For more information visit
VehicleServicePros.com/21136641

IDENTIFIES VEHICLE AND BATTERY INFORMATION QUICKLY

The **Autel MaxiBAS BT609** is a 7" Android-based touchscreen, Wi-Fi tablet that can display a quick health status of an existing battery, register a new battery, and perform advanced battery and electrical system diagnostics. The BT609 supports in-vehicle and out-of vehicle testing of 6V and 12V, 100 – 3000 CCA, flooded, AGM, AGM Spiral, EFB, and gel batteries and 12V and 24V cranking/charging systems. The BT609 also features AutoVIN and VINScan to immediately identify vehicle and battery information and to display graphic instructions for battery positioning and testing. In addition, the BT609 is an all systems code reader and offers a large menu of commonly performed maintenance services.

For more information visit
VehicleServicePros.com/21155561



OFFERS NINE RESET FUNCTIONS

The **Matco Tools Maximus Lite Diagnostic Scan Tool**, No. MDMAXLITE, is an Android-based code reader that features full coverage ABS, airbag, engine, and transmission codes, live data, and graphing in a basic mode. In addition, it offers nine reset functions: oil reset, EPB, battery, injector relearn, DPF, SAS, IMMO, brake bleed, and TPMS relearn database. The scan tool is easy to navigate with both a 5" touchscreen and thumb pad navigation. Wi-Fi enabled, it allows for one-click automatic updates, as well as provides automatic health reports with an email feature and MAXVIN for quick vehicle identification. Add individual makes (all module) enhanced coverage with pay-by-month subscriptions.

For more information visit
VehicleServicePros.com/21130534

INCLUDES UNIVERSAL DIESEL AND GASOLINE ADAPTERS

The **Ansed Diagnostic Solutions HU35025 Universal Digital Pressure Tester** is able to measure diesel and gasoline compression, oil pressure, turbo pressure, cooling system pressure, AD Blue pressure, fuel low and high pressure, vacuum pressure, particle filter pressure, and exhaust back pressure. With a 7" Color TFT touchscreen display, it's easy to learn and easy to use. Technicians are able to save, export to a computer, print, and share all the results. The kit includes a universal diesel compression adapter, universal gasoline adapter, other necessary adapters, as well as two sensors. The tester is multilingual: English, French, and Spanish.

For more information visit
VehicleServicePros.com/21154163



COMBINES MEASUREMENT AND INFRARED CAPABILITIES

The **FLIR Thermal Camera**, No. TG275, is designed for automotive maintenance and repair technicians for diagnosing problems in relays and switches, parasitic drain on the battery, drivetrain components, HVAC system (vents), and more. Featuring infrared guided measurement (IGM), the diagnostic tool combines non-contact temperature measurement and thermal imaging to help troubleshoot repairs, spot potential faults, and record images to reassure customers that the problem has been fixed. It has a temperature range up to 1,022 degrees F, is drop-tested with an IP54 enclosure, and can hold up to 50,000 images. It also features a laser for precise measurements and a visible camera that provides additional context and clarity.

For more information visit
VehicleServicePros.com/21113424



ABLE TO DELIVER COMPLETE TPMS SERVICE, DIAGNOSTICS, AND SUPPORT TIRE SERVICE

The **Continental Autodiagnos TPMS D** is designed to read and diagnose all OE and 20 aftermarket TPMS sensor brands on the market, helping shops optimize their investment in TPMS and tire service. It can also perform relearns on 98.6 percent of all domestic, European, and Asian TPMS compliant vehicles. The tool can read and clear TPMS codes, has a built in VIN scanner for faster make/model/year lookups, and can program sensors from historical data. It also features easy-to-use software, connects to Wi-Fi for software updates and downloads of the latest vehicle applications, and can be easily read in direct sunlight.

For more information visit
VehicleServicePros.com/21144665

FEATURES A COMPACT AND ERGONOMIC INTERFACE

The **TEXA Navigator NANO S** allows technicians to complete all diagnostic tests quickly and easily on passenger cars, light commercial vehicles, diesel pickups, and high-end supercars. The compact, lightweight, and ergonomic interface is designed to function simply and automatically with IDC5 installed on TEXA's AXONE Nemo, or any Windows-based laptop or tablet. An inspection light illuminates the diagnostic socket, making it clearly visible on the vehicle. An LED is also located on the front of the unit, facing the technician, in order to signal the correct functioning of the unit. At the end of the diagnostic tests, the Navigator NANO S emits a distinctive beep to remind the technician to disconnect the unit.



For more information visit
VehicleServicePros.com/21131903

FEATURES STEP-BY-STEP REPAIR INSTRUCTIONS

Noregon's NextStep Repair is an interactive resource of step-by-step repair instructions and guidance for all engine makes and models. NextStep Repair allows technicians to quickly locate the correct repair information for a wide range of component manufacturers. It contains detailed removal, inspection, and installation instructions, scalable images and diagrams, cautionary details, step-by-step repair instructions, and testing procedures. These features give technicians all the information necessary to manage complicated repairs using a single site. NextStep Repair is offered as an add-on solution with JPRO Professional or available as a standalone option for technicians seeking to enhance their current diagnostic process with a central repository of repair procedures.

For more information visit
VehicleServicePros.com/21150780



QUICKLY TESTS ELECTRONIC CONTROL VALVES

The **Robinair Electronic Variable Compressor Tester**, No. EVDC100, enables technicians to quickly test electronic control valves in variable displacement compressors to determine if functioning correctly and eliminating compressor misdiagnosis. The EVDC100 works by varying voltage supplied to the refrigerant control valve on the compressor to verify valve function, mimicking a properly functioning compressor valve for a quick and accurate diagnosis. It's designed to work with multiple variable displacement compressors. Powered by the vehicle's battery, the tester's connector adapters work on both old and newer style compressors and include heavy duty battery clips. It also includes a 6' wiring harness and removable cable assemblies for easy replacement.

For more information visit
VehicleServicePros.com/21154914



ABLE TO REPROGRAM DOMESTIC, ASIAN, AND EUROPEAN VEHICLES

The **Snap-on Pass Thru Assistant** expands automotive repair and collision technicians' J2534 programming capabilities, making it easy for them to keep vehicles in the shop, finish the job correctly, and increase profits and customer satisfaction, the company says. The Pass Thru Assistant reprograms domestic, Asian, and European vehicles with the same easy-to-use process. It supports brands including BMW, Chrysler, Ford, GM, Honda/Acura, Hyundai, Kia, Mercedes-Benz, Nissan, and Toyota/Lexus/Scion. The kit contains a Windows tablet PC, J2534 device, 4G modem, and a 90A battery maintainer capable of handling European amperage requirement.

For more information visit
VehicleServicePros.com/21150977





MAXIMIZE UPTIME

UPGRADE YOUR REPAIR PROCESS.

Improve your shop efficiency to maximize uptime. Pair JPRO® Professional with NextStep® Repair for the most comprehensive diagnostic and repair tool available today. JPRO gives technicians the tools to thoroughly diagnose and troubleshoot vehicle issues and NextStep Repair's step-by-step instructions remove the guesswork from repair work.

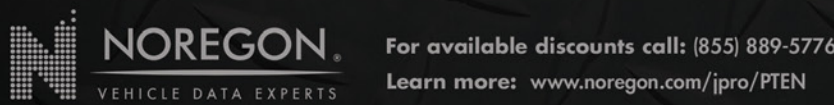

For available discounts call: (855) 889-5776
Learn more: www.noregon.com/jpro/PTEN



LEARN MORE /
VIEW COVERAGE

©2020 Noregon. JPRO and NextStep are registered trademarks of Noregon. All Rights Reserved.

For more information visit VehicleServicePros.com/10122188